

结构图 *Structural drawing*

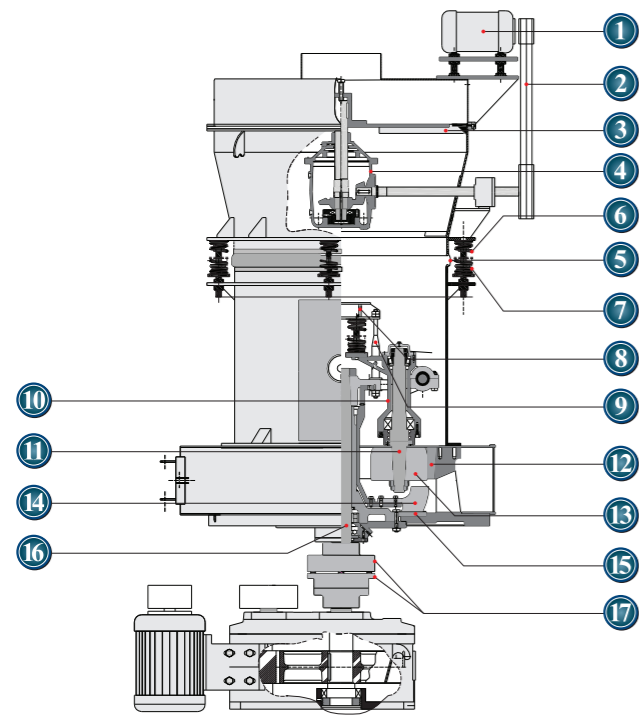

主机示意图
Mainframe Diagram

- | | |
|-----------|------------------------------------|
| 1. 电机 | 1. Motor |
| 2. 三角带 | 2. Triangle Belt |
| 3. 叶片 | 3. Impeller Blade |
| 4. 油池 | 4. Classifier Oil Box |
| 5. 软连接工业布 | 5. Soft Connecting Industria Cloth |
| 6. 弹簧定位套 | 6. Spring Orientation Cover |
| 7. 弹簧 | 7. Spring |
| 8. 弹簧座 | 8. Spring Base |
| 9. 弹簧拉杆 | 9. Spring Pull Staff |
| 10. 磨辊轴承室 | 10. Roller Bearing Room |
| 11. 磨辊轴 | 11. Roller shaft |
| 12. 磨环 | 12. Ring |
| 13. 磨辊 | 13. Roller |
| 14. 铲刀 | 14. Spade |
| 15. 铲刀座 | 15. Spade Base |
| 16. 主轴 | 16. Main Shaft |
| 17. 连轴器 | 17. Reducer&Main Connector |

全套设备示意图
Diagram for the complet set

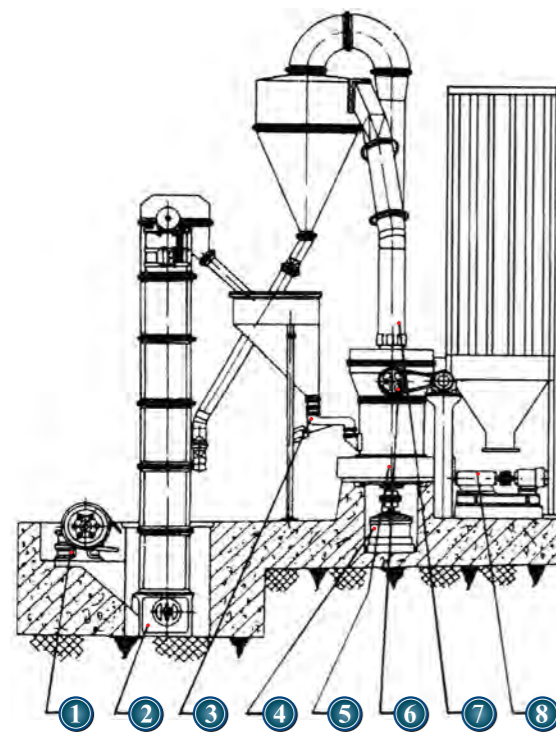

- | | |
|------------|--------------------------------------|
| 1. 颚式破碎机 | 1. Jaw Crusher |
| 2. 斗式提升机 | 2. Bucket Elevator |
| 3. 电磁振动给料机 | 3. Electro-magnetic Vibrating Feeder |
| 4. 传动装置 | 4. Transmission Devices |
| 5. 主机 | 5. Roller Mill |
| 6. 分析机 | 6. Classifier |
| 7. 管道装置 | 7. Pipe |
| 8. 鼓风机 | 8. Blower |

注：此为 YGM9518 型以上大型配套装置，小型所需颚式破碎机、斗式提升机、电磁振动给料机，可根据用户需要选购。

Note: These are large-scale necessary equipment for YGM9518 and high-pressure 9518 grinder mill. For smaller equipment, it just needs jaw crusher, bucket elevator, electro-magnetic vibrating Feeder. According to clients need, it can be chosen as separate part.



技术参数 *Specification*

型号 Model	磨辊 Roller			磨环 Ring		最大进料粒度 Stuff Size (mm)	成品粒度 Fineness of product (mm)	主机功率 (Kw) Power for main roller mill
	个数 Number	直径 (mm) Diameter	高度 (mm) Height	内径 (mm) Inside Diameter	高度 (mm) Height			
YGM7815	3	260	150	780	150	< 15	0.613-0.033	18.5
YGM8514	3	270	140	850	140	< 20	0.613-0.033	22
YGM9518	4	310	180	950	180	< 25	0.613-0.033	37
YGM4121	5	410	210	1280	210	< 25	0.613-0.033	75
YGM4528	6	450	280	1600	280	< 35	0.613-0.033	132

型号 Model	成品细度 (mm) Fineness of product			
	0.25	0.125	0.075	0.044
	产量细度 (t/h) capacity			
YGM7815	1.7-4	1.5-3.0	1.1-2.2	0.8-1.4
YGM8514	2.0-5	1.8-4.6	1.3-2.8	1.0-2.0
YGM9518	2.5-6.6	2.0-5.6	1.8-3.6	1.3-3.0
YGM4121	3.0-10	2.3-6.8	2.0-4.5	1.8-4.0
YGM4528	6.0-20	4.6-13.6	4.9-9.0	2.6-8.0

注明：详细参数以说明书为准。